

FLAT PREHEATER RETROFIT INSTRUCTIONS

EnergyLogic has developed a new oil preheater design that uses a flat, finned extrusion to provide surface area for heat transfer. The design is backwards compatible with the retrofit kit, but the oil inlet is in a different location, so the copper tubing from the pump will need adjusting. The new preheater is similar to the previous design in that it uses standby and run PTC heaters, as well as a thermostat to ensure that the oil is heated before allowing the burner to fire.

The main advantage of the new design is that the electrical components (heaters and thermostat) are on the outside. This allows them to be easily removed, so the extrusion and cover can be cleaned in a parts washer, the electrical components can be easily replaced if one fails, and the PTC heaters can be changed to allow the preheater to be used on different models.

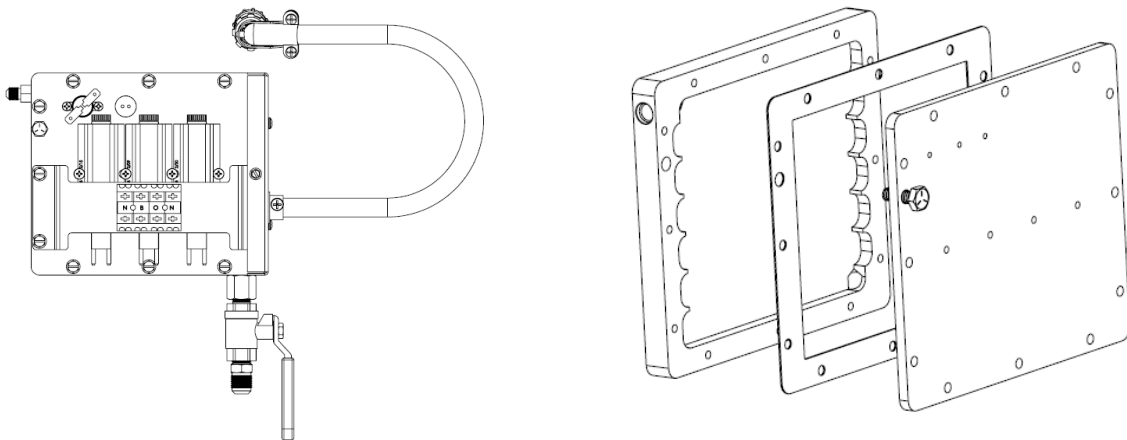

The preheater mounts to the burner chassis. It slides into a sheet metal cover as shown below.

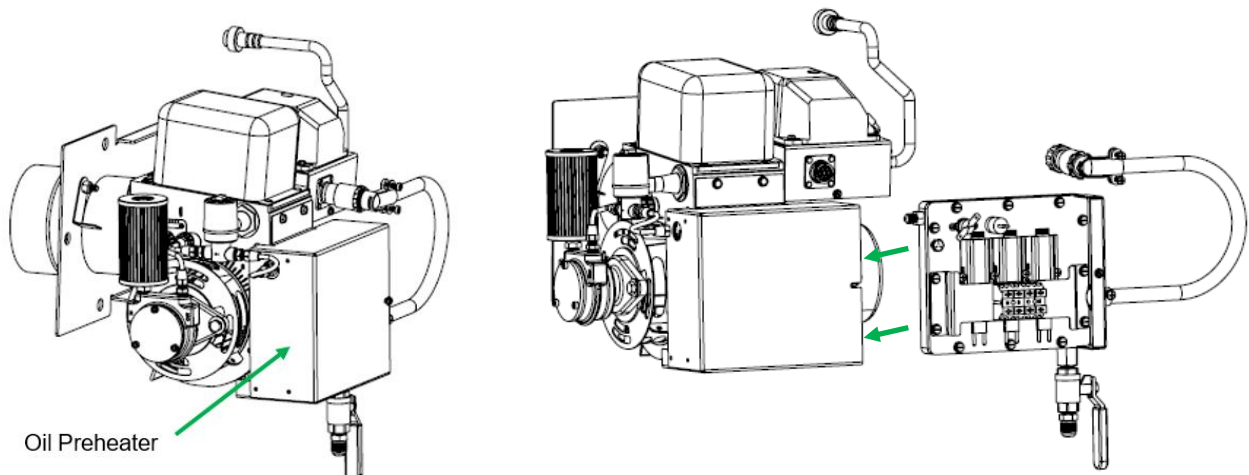

STEPS TO RETROFIT NEW PREHEATER ON EXISTING BURNER:

1. Unplug the existing preheater and disconnect the oil lines from the inlet and outlet. Drain the oil from the preheater. CAUTION – Oil may be hot.
2. **Models 140H, 200H, and 350H:** Remove the long bolt and washer that holds the preheater to the air compressor on the side of the burner. Install the shorter bolt and washer provided with the kit into the air compressor.

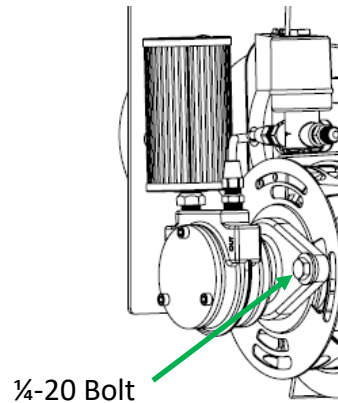

3. **Model 200B:** Remove the long bolt(s) and washer(s) holding the preheater to the burner chassis. Remove the standoff hardware.
4. Locate the sheet metal cover on the burner as shown below. Using a drill with a 5/16-inch nut driver, secure the cover in place with the four self-drilling screws. CAUTION – First flip open the ignition transformer and make sure there are not any wires inside the burner chassis in the area where the screws could hit them.

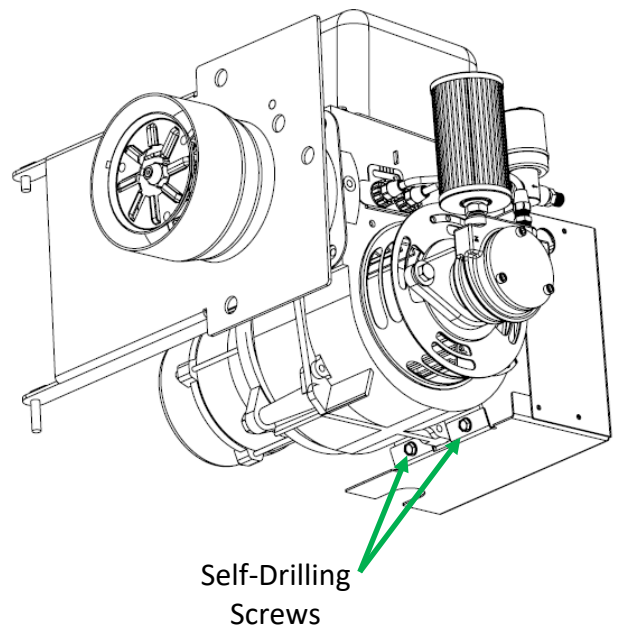
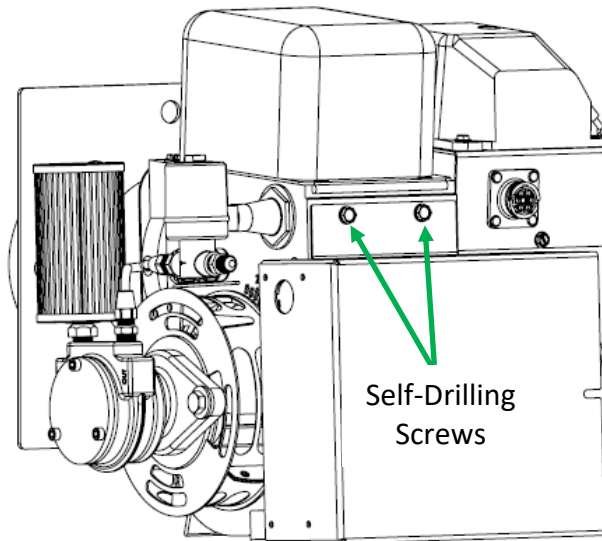

- Slide the preheater assembly into the cover box, so the oil outlet fitting protrudes through the hole in the left side. Lock it in place with the set screw. **CAUTION** – Take care not to catch any of the wires. Bend the cable and plug it into the receptacle on the burner wiring box.

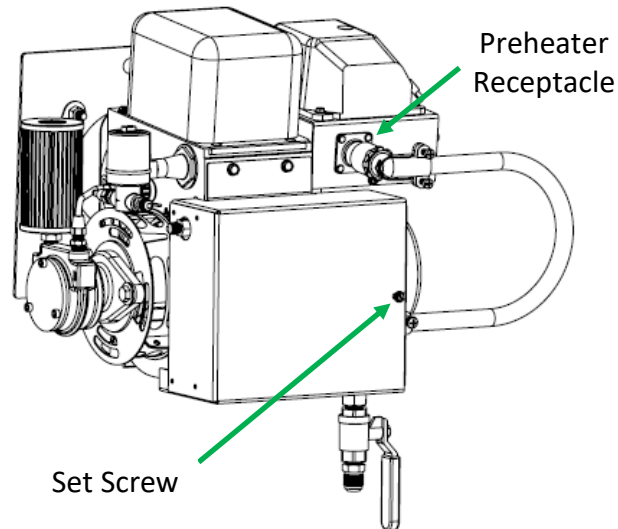

- Connect the oil supply tubing from the pump to the inlet fitting on the bottom of the preheater. **NOTE** – Some relocation of the line will be required.
- Prime the preheater using the standard procedure (shown in furnace or boiler manual). Prime until oil is flowing steadily from the outlet fitting on the top left side of the preheater, with no air bubbles. Use an empty bottle or bowl to catch the oil as it comes out. **CAUTION** – The oil may be hot.
- Install the bent copper tube between the preheater and the solenoid valve using two 7/16-inch wrenches. (One to tighten the nut and one to hold the mating fitting.)

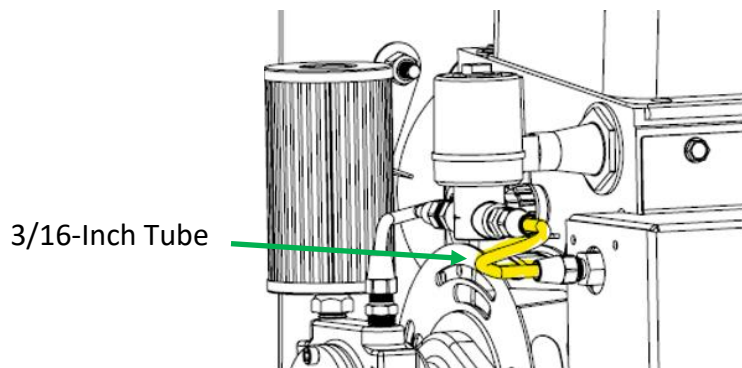

- Once the preheater is hot, test fire the burner to ensure it is working properly.

If you have any questions, contact your local dealer or EnergyLogic Technical Support at 800-351-0643.



HEATER WIRING DIAGRAM
MODELS: 140H, 200H, AND 350H

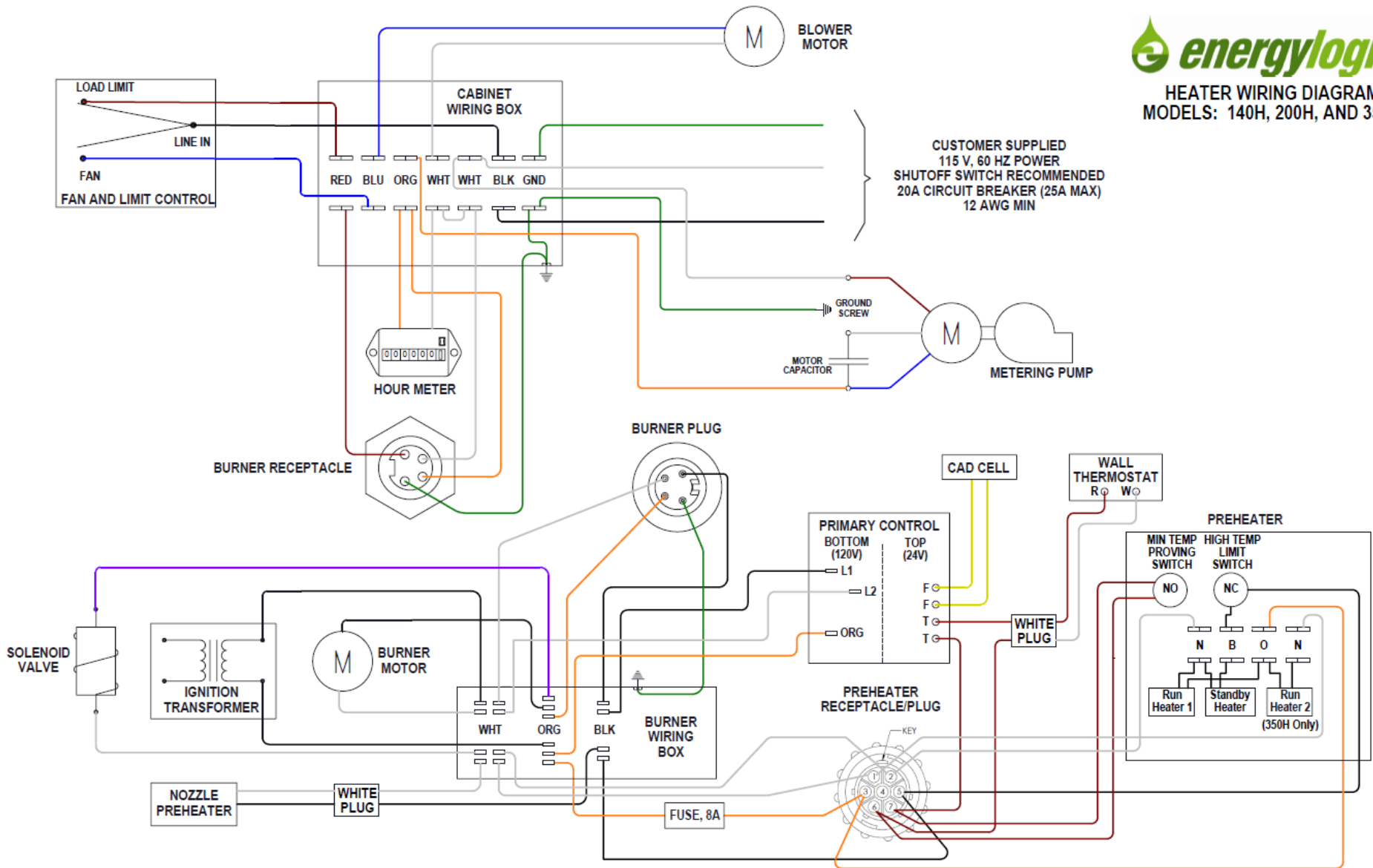

ITEM: 81012232 - WIRING DIAGRAM, FLAT PREHEATER RETROFIT RELEASED: 08/7/2024

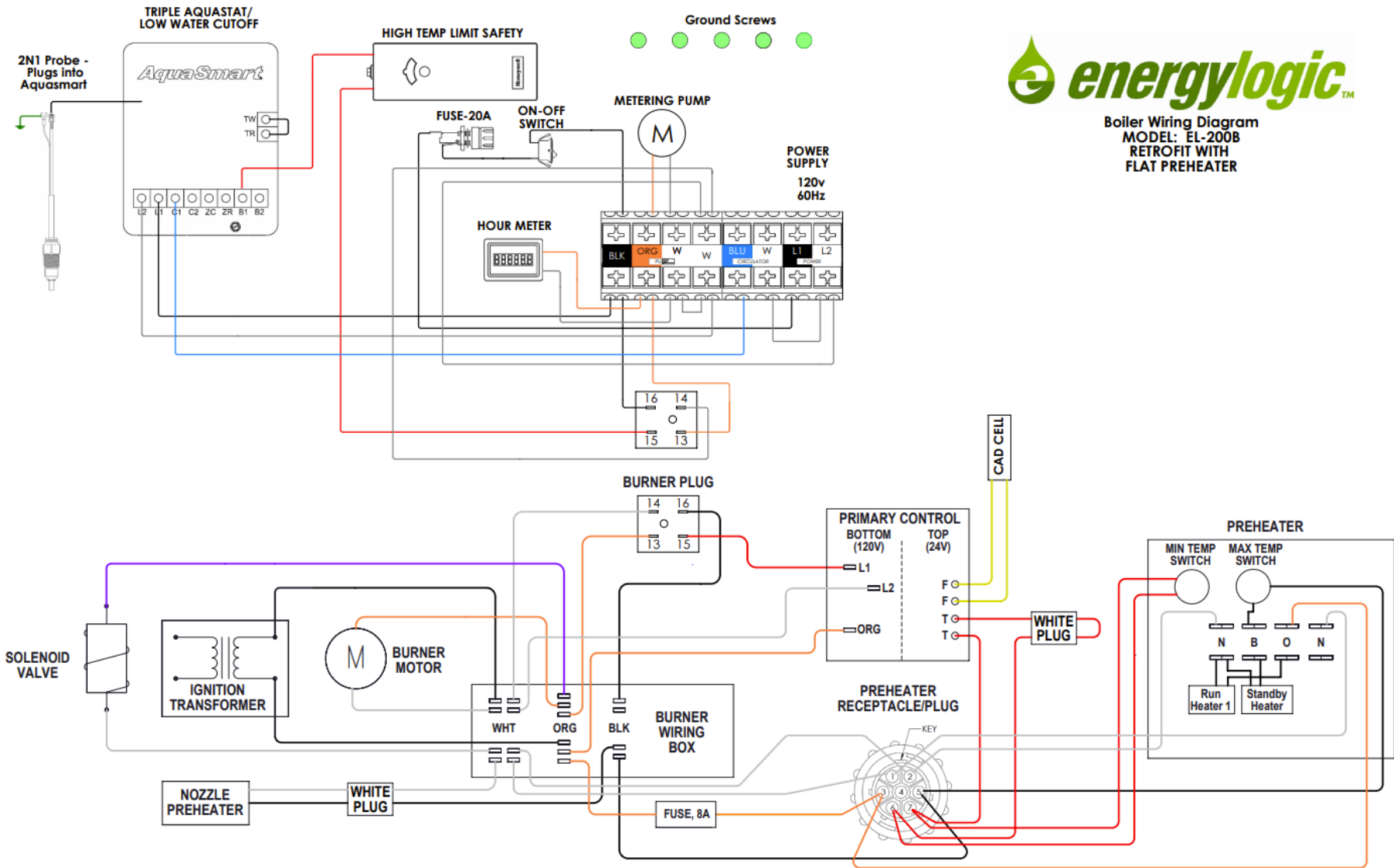

ITEM: 81012660 - WIRING DIAGRAM, EL-200B FLAT PREHEATER RETROFIT RELEASED: 04/30/2025

Preheater Cleaning

How often?

Once per year, or as needed.

Tools Required:

¾" wrench, 7/16" wrench (x 2), adjustable wrench, Phillips screwdriver, ¼" and 5/16" nut drivers, torque wrench, wire brush, safety glasses, rubber gloves.

Replacement Parts:

Preheater Gasket – Part #: 76001184, Inlet O-Ring – Part #: 76001386, Outlet O-Ring – Part #: 76001205

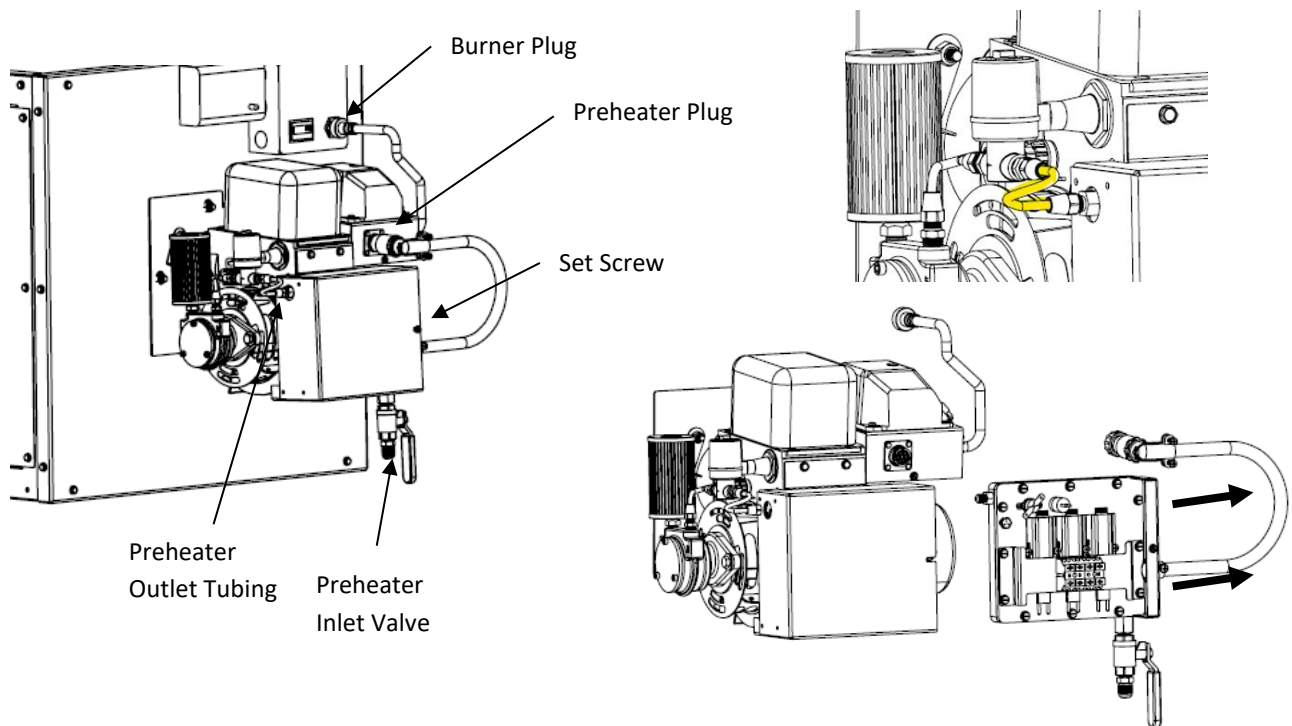

Removing Preheater from Burner

Procedure - All Models (refer to figures):

1. Wear all safety equipment.
2. Unplug the burner at the cabinet wiring box by first rotating the connecting ring counterclockwise until it is loose and then pulling out the plug.
3. Unplug the preheater at the burner wiring box by first rotating the connection ring counterclockwise until it is loose and then pulling out the plug. Allow the preheater to cool.

⚠ CAUTION Until the preheater has cooled, the parts and the oil are hot.

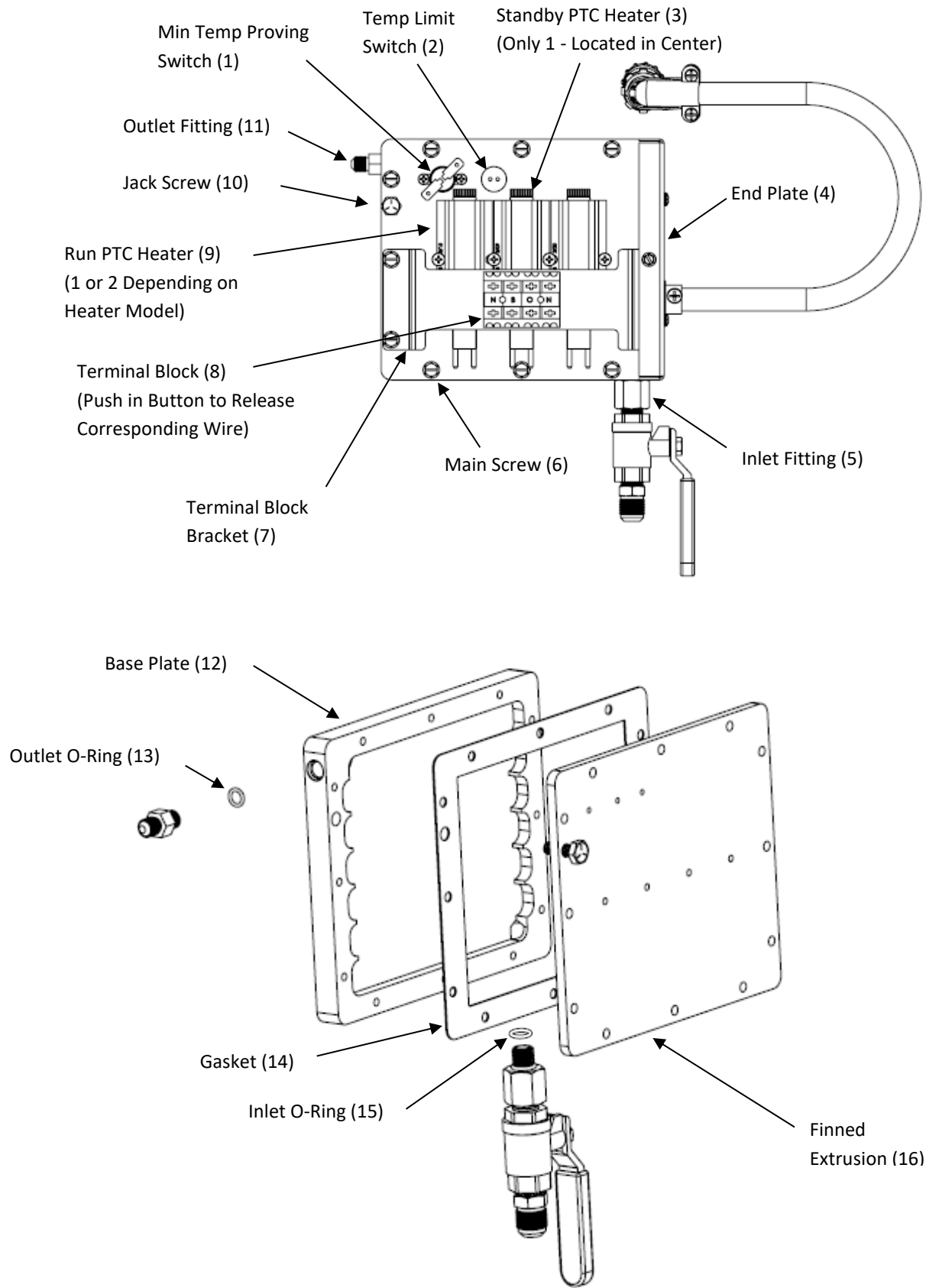

Preheater Components

(The 200B has an additional elbow on the inlet.)

4. Close the preheater inlet valve and disconnect the fuel tubing from the inlet and outlet ports of the preheater. **NOTE:** Use one wrench to keep the fitting connected to the preheater from turning, and a second wrench to loosen the flare nut. Have a rag ready to soak up oil that spills.
5. Loosen the set screw and slide the preheater out of its mounting box. Keep the preheater vertical to keep oil from leaking out.
6. Hold the preheater over a bucket or an opening in your tank and open the hand valve to allow the oil to drain from the preheater.

NOTE: Prior to disassembling the preheater, it is recommended that you take a picture for reference later. Refer to figures on the previous page.

NOTE: DO NOT disassemble the preheater unless you have a replacement gasket and o-rings. The existing ones may not be reusable. These can be purchased individually or are included in the Burner Maintenance Kits – Part #: 81012154 for the 140H/200H, 81012155 for the 350H and 81012168 for the 200B.

7. Remove the two screws holding the Proving Switch (1).
8. Disconnect the Temp Limit Switch (2) wires and unscrew it from the block. **NOTE:** Gently use pliers on the brass base to turn it counterclockwise.
9. Remove the two screws holding the End Plate (4) to the block.
10. Remove the screws holding the PTC heaters (3 and 9).
11. Remove the four Main Screws (6) holding the Terminal Block Bracket (7).
12. Remove the entire electrical assembly without disconnecting the wires and set aside.
⚠ CAUTION DO NOT submerge any of the electrical components in oil or cleaning fluid or they will be damaged. Handle the wiring carefully.
13. Remove the remaining Main Screws (6).
14. Tighten the Jack Screw (10) to separate the Finned Extrusion (16) from the Base Plate (12).
15. Remove the old Gasket (14) from the Base Plate and/or Finned Extrusion.
⚠ CAUTION Be careful not to damage the machined surfaces where the gasket seats, or leaks may occur after reassembly.
16. Unscrew the Inlet and Outlet Fittings (5 and 11) from the Base Plate and remove the O-ring Seals (13 and 15).
17. Use a wire brush and parts washer fluid to clean the Finned Extrusion, Base Plate, and Fittings. Clean thoroughly to remove all loose debris that could come loose and block the nozzle. **NOTE:** It is okay to soak the metal parts in cleaning fluid.
18. Once the parts are clean and dry, reassemble in reverse order. Use a new Gasket (14) and O-rings (13 and 15) to prevent leaks.
19. Loosen the Jack Screw (10), so it does not prevent the plates from coming together.
20. Install the Terminal Block Bracket (7) with four Main Screws (6), hand tight.
21. Install the remaining Main Screws (6), hand tight.
22. Torque all the Main Screws to **35 in-lbs** in a crisscross pattern, starting with the center of each side and working to the corners.
23. Reinstall the End Plate (4) and all the electrical components. Then reconnect the Temp Limit Switch (2) wires that were disconnected.
24. Reinstall the Inlet and Outlet Fittings (5 and 11) with new O-rings Seals (13 and 15).
25. Remount the Preheater onto the burner.
26. Reconnect the fuel tubing to the inlet and outlet fittings of the Preheater.

27. Refer to Section 7.4.1. “Fuel System Priming” for the priming procedure to ensure no air remains in the fuel system.
28. Make sure no leaks are present around the Preheater.

⚠ WARNING Make sure to perform startup and system checks, as described in the installation and operating manual, after every maintenance cycle. Record the checks, maintenance performed, and gauge readings in the maintenance log.

If you have any questions, contact your local dealer or EnergyLogic Technical Support at 800-351-0643.